

LANCIA TONDA

design: P. Pepere



made in Italy

U 1575

Ø 78,74"

/W - LED 67W 7560lm 4000K CRI>90**/WW - LED** 67W 7140lm 3000K CRI>90**/XW - LED** 67W 6720lm 2700K CRI>90

U 1576

Ø 118,11"

/W - LED 96W 10800lm 4000K CRI>90**/WW - LED** 96W 1012 lm 3000K CRI>90**/XW - LED** 96W 9600 lm 2700K CRI>90

Solo l'uso corretto delle istruzioni garantisce la sicurezza dell'apparecchio:

E' NECESSARIO CONSERVARLE

L'installazione e la manutenzione dell'apparecchio deve essere fatta esclusivamente da personale specializzato. Disinserire la tensione prima di ogni intervento sull'apparecchio. Per un corretto montaggio vedere lo schema allegato. Questo prodotto contiene una sorgente luminosa di classe di efficienza energetica F. **EU2019/15**

This equipment is guaranteed only if used as indicated in these instructions:

PRESERVE THIS INSTRUCTIONS

The fitting has to be installed and maintained only by qualified staff.

Before any operation on this equipment, disconnect the power supply.

For a correct assembling see the here enclosed diagram. This product contains a light source of energy efficiency class F. **EU2019/15**

La sécurité de l'appareil n'est garantie que par le respect des instructions suivantes.

IL EST NECESSAIRE LES CONSERVER

L'installation et l'entretien de l'appareil doivent être faits exclusivement par du personnel qualifié. Disjoindre le courant de réseau avant tout operation sur l'appareil. Pour le montage suivre le schéma ici joint. Ce produit contient une source lumineuse de classe énergétique F. **EU2019/15**

Nur bei Befolgung der nachfolgenden Anweisungen, ist die Sicherheit des Gerats gewährleistet.

AUFBEWAHREN SIE BITTE DIE ANWEISUNGEN

Die Installation und die Unterhaltung des Geräts müssen ausschliesslich durch qualifiziertes Personal erfolgen. Abschalten die Netzspannung vor Ausweshlsen der lampe. Fur eine einwaldfrei Montage siehe Beigefutges. Dieses Produkt beinhaltet eine Lichtquelle der Energieeffizienzklasse F. **EU2019/15**

Solamente el correcto cumplimiento de las instrucciones puede garantizar la seguridad del aparato:

ES NECESARIO CUMPLIRLAS.

La instalación y mantenimiento del aparato deben realizarse por un profesional. Desconectar la tensión antes de cualquiera intervención en el aparato. Para un ensamblaje correcto, consultar el esquema adjunto. Este producto incluye una fuente de luz de clase energética F. **EU2019/15**



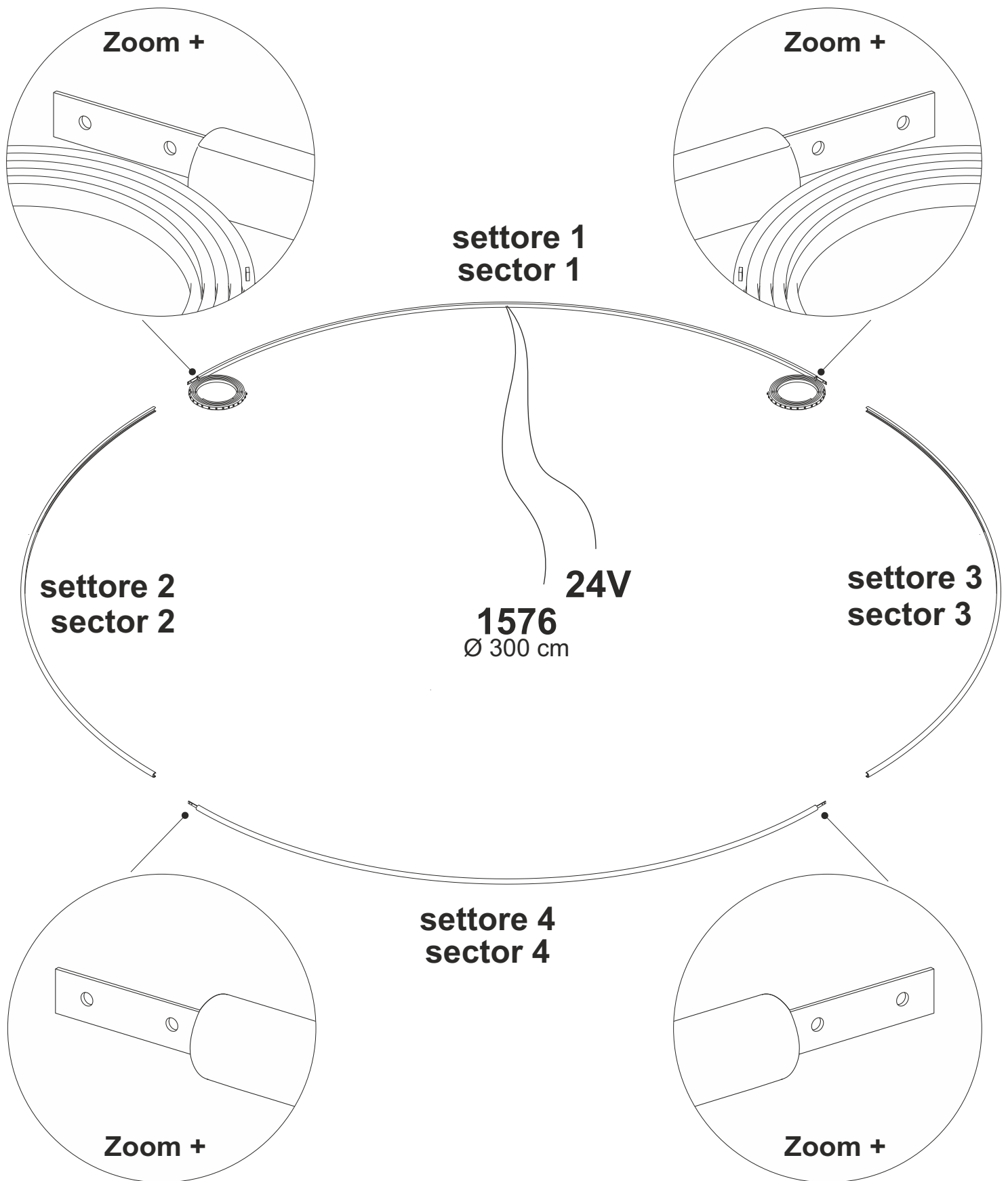

Assemblaggio dei 4 settori a terra
Assembly of the 4 sectors on the ground

A

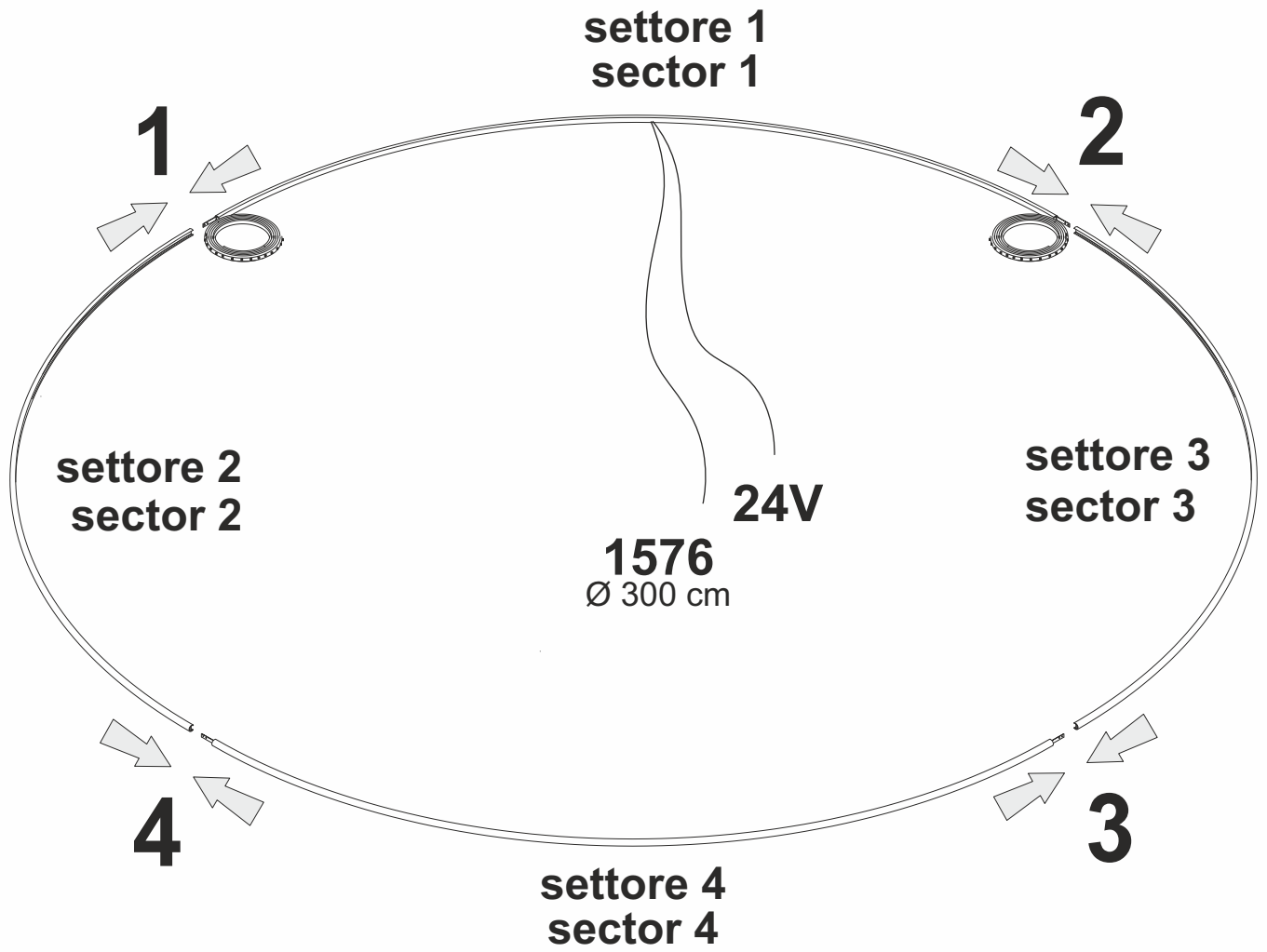

B

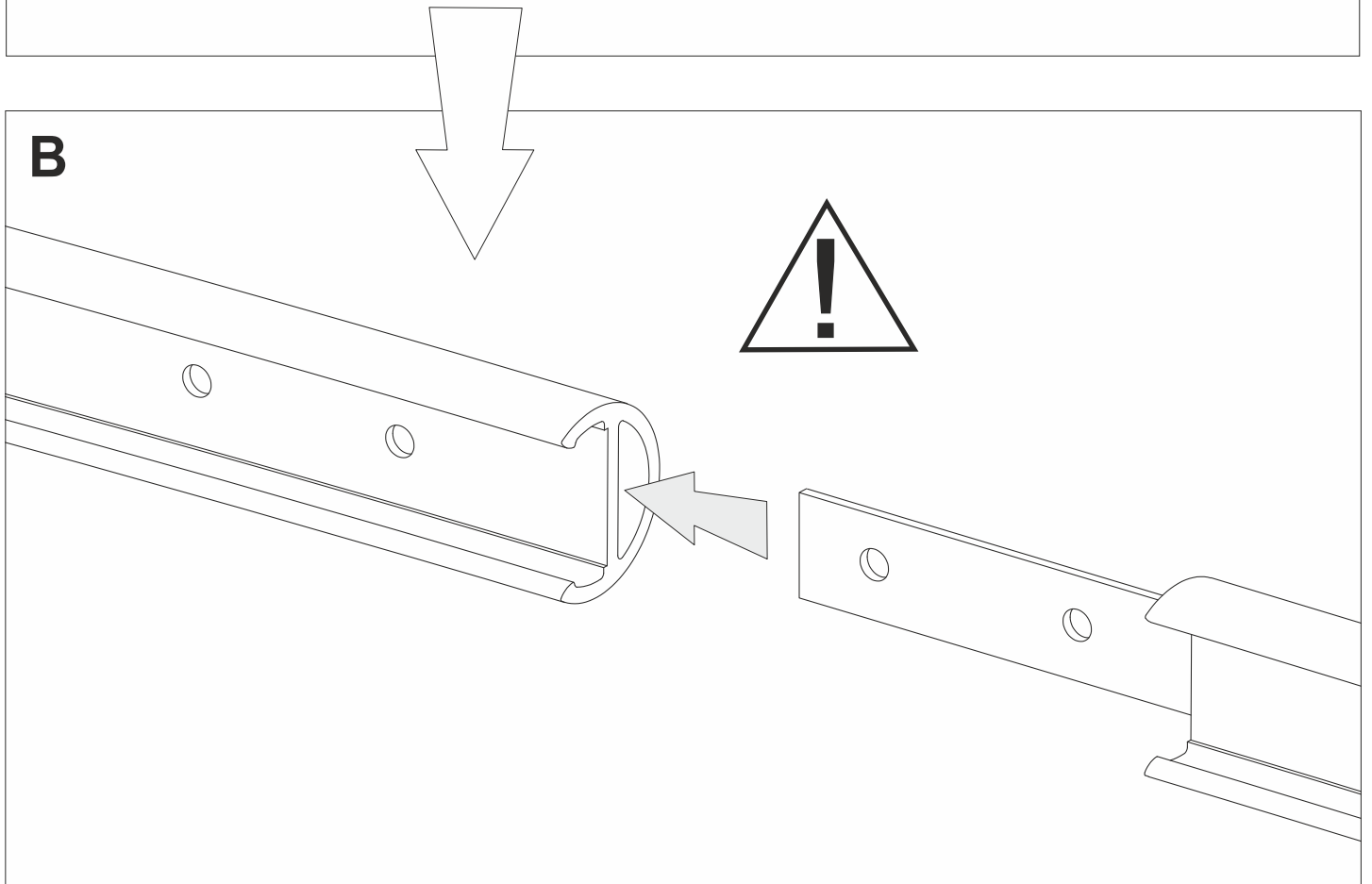

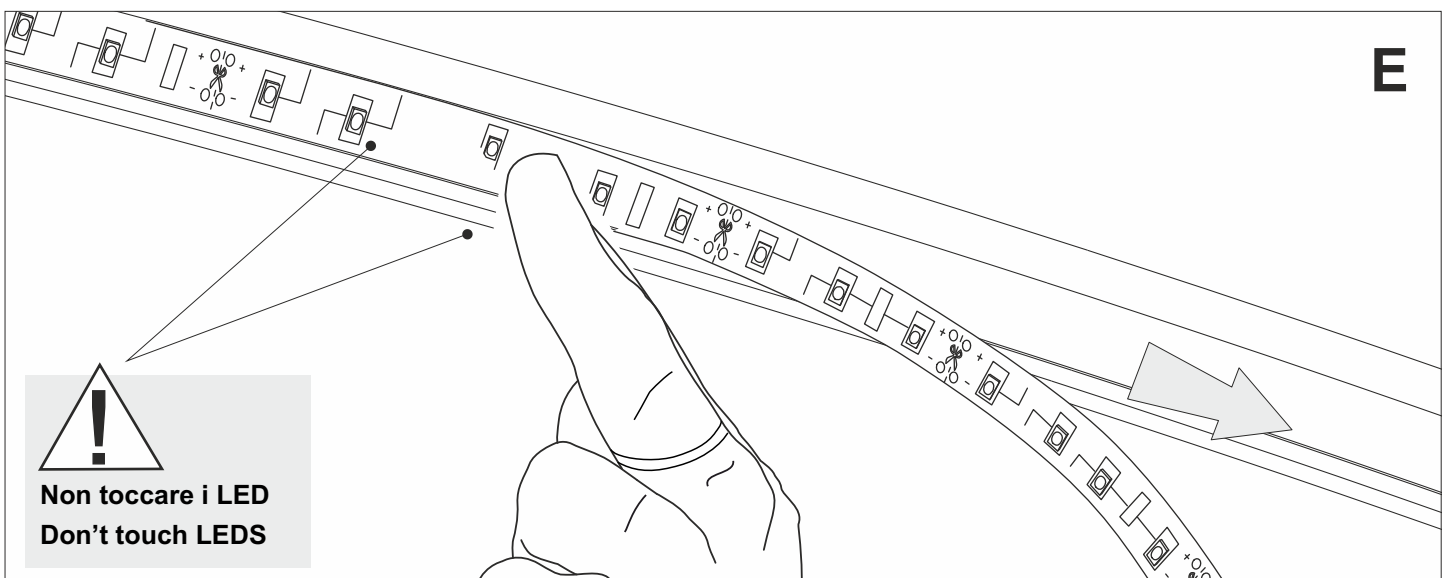
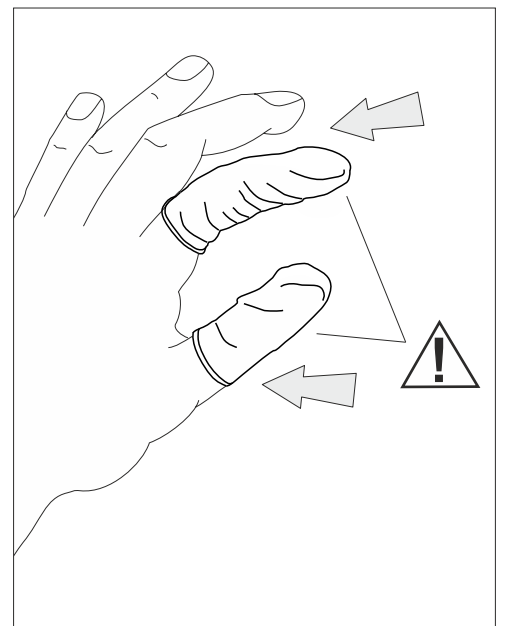
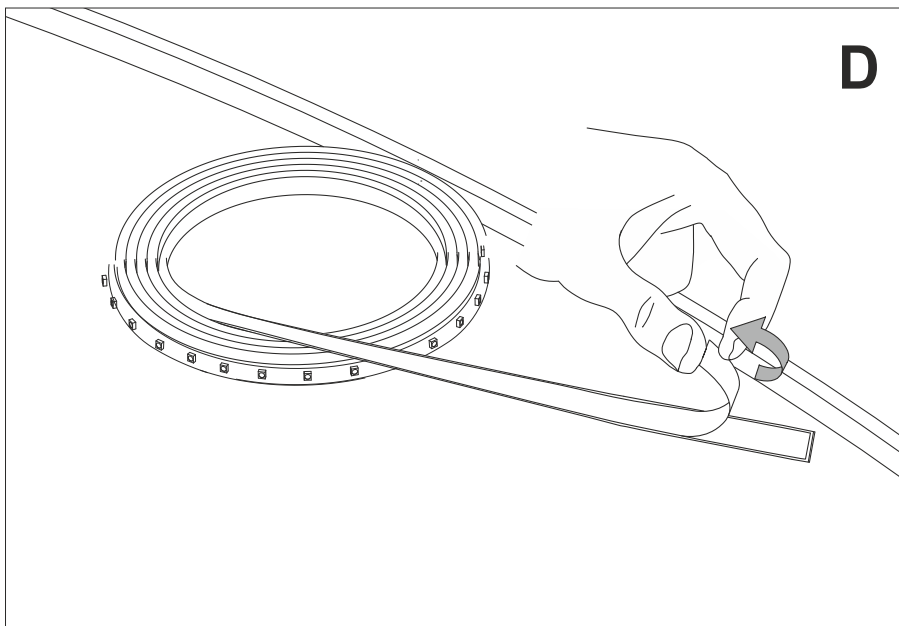
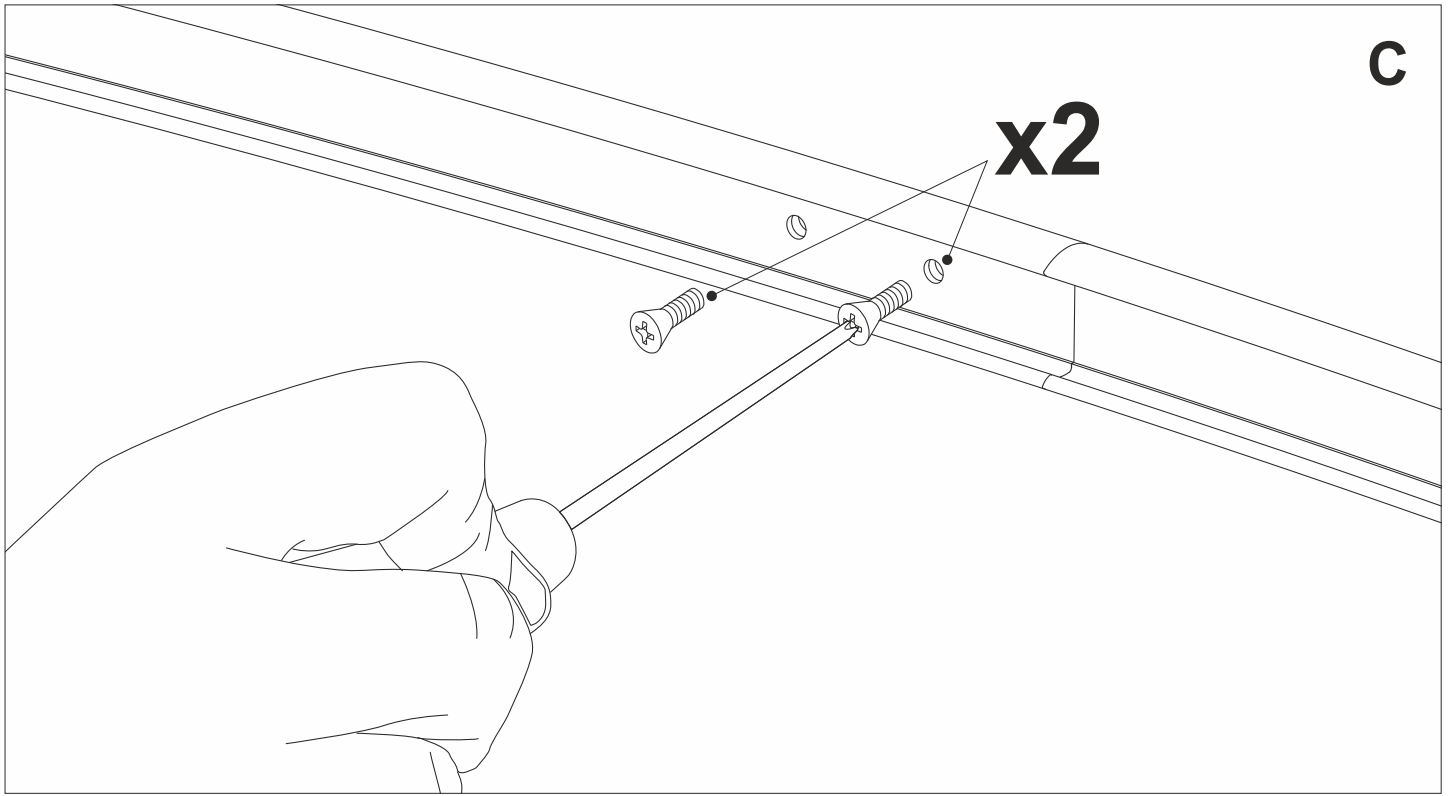

F

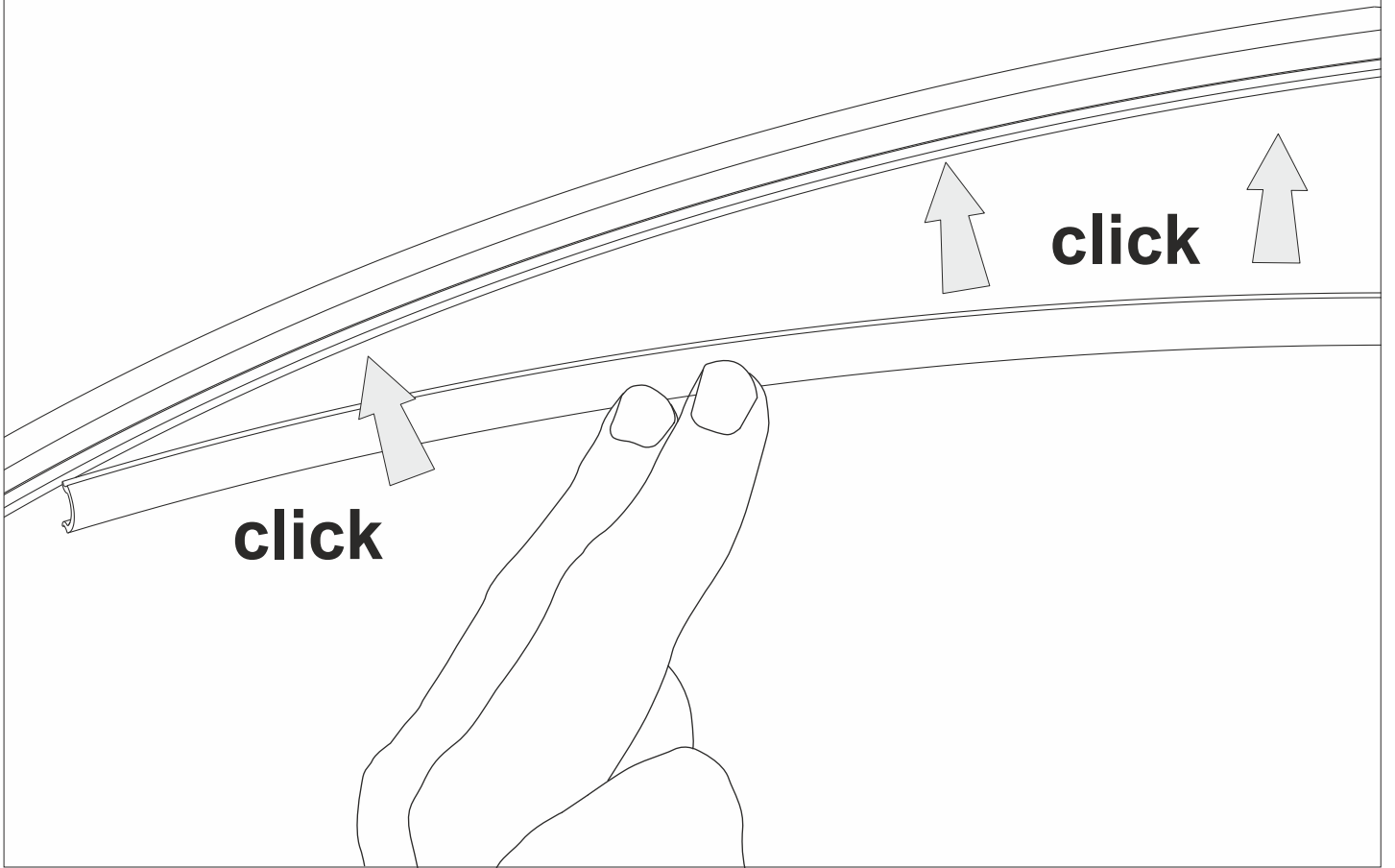

ok

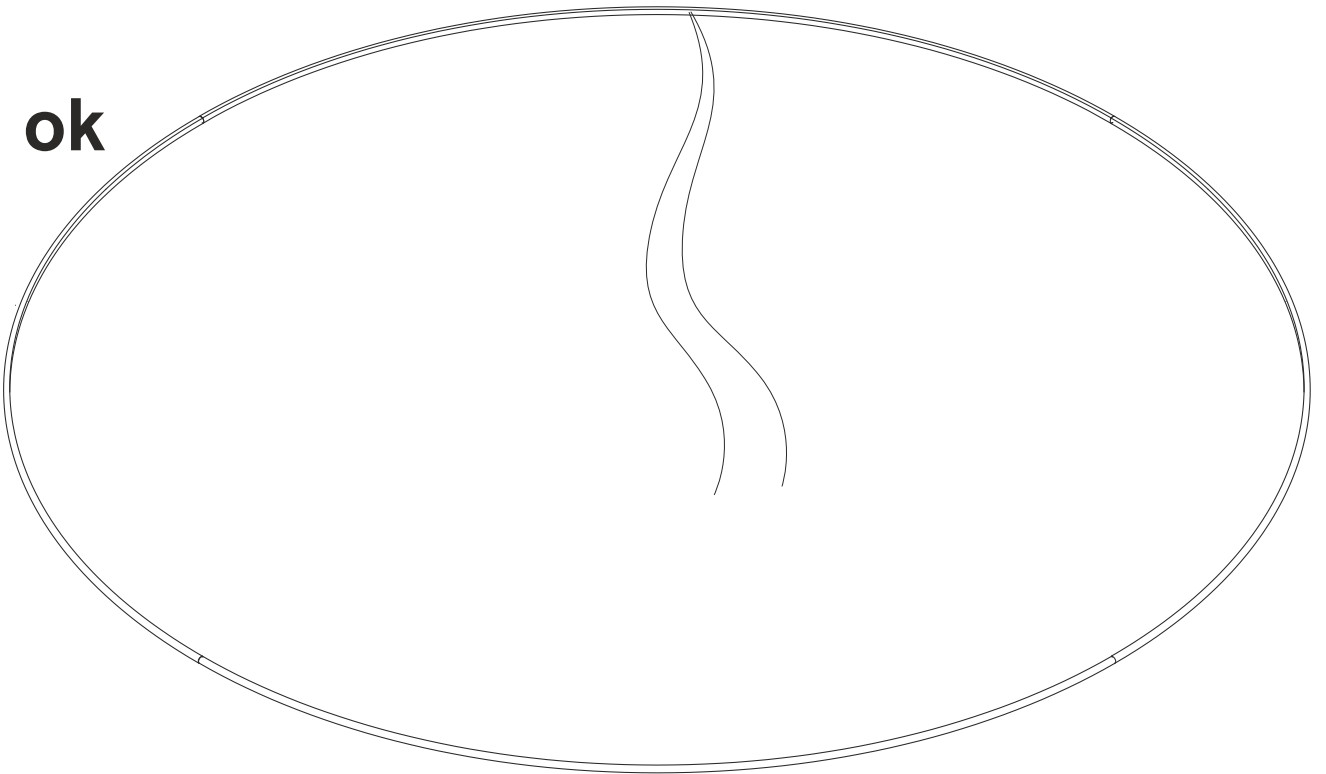

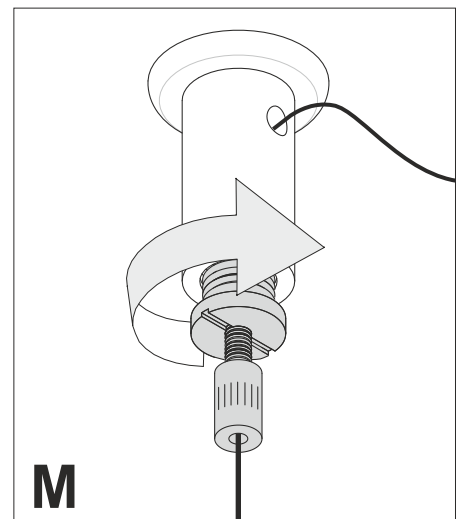
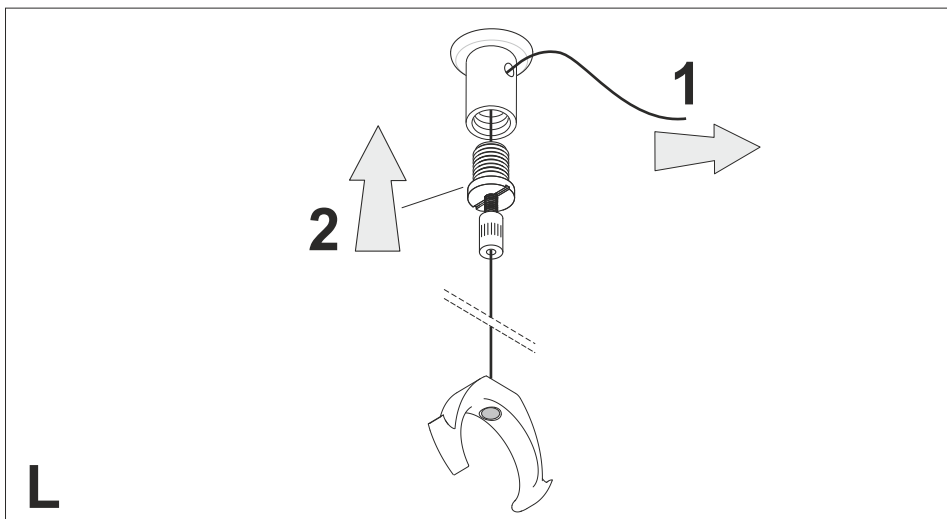
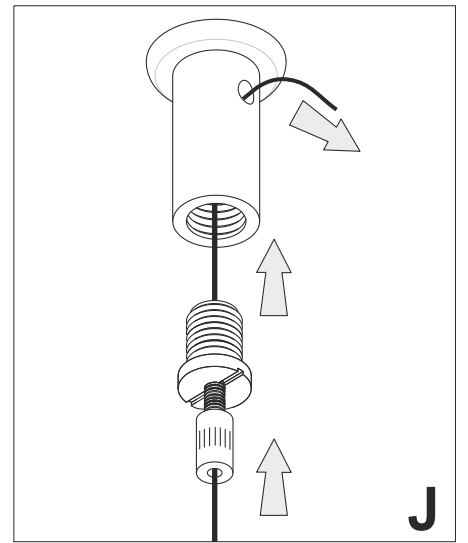
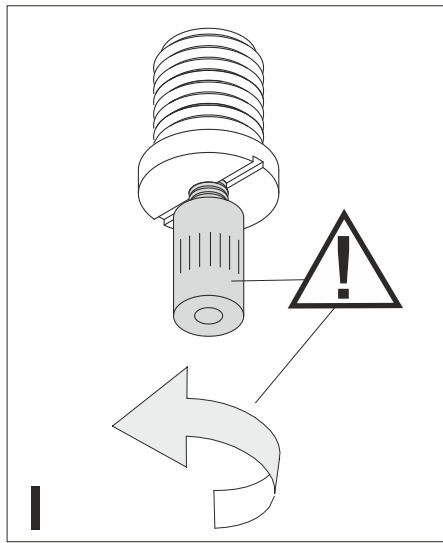
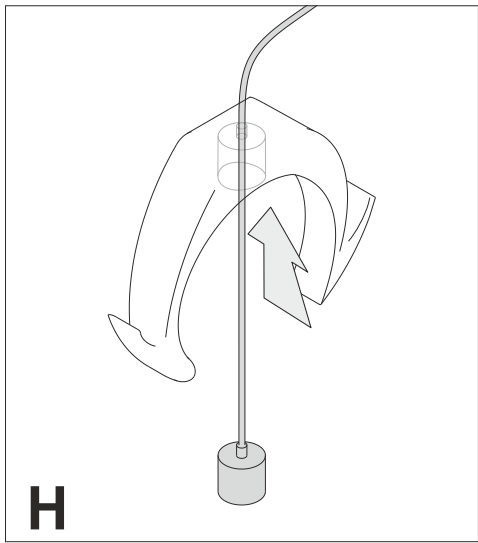
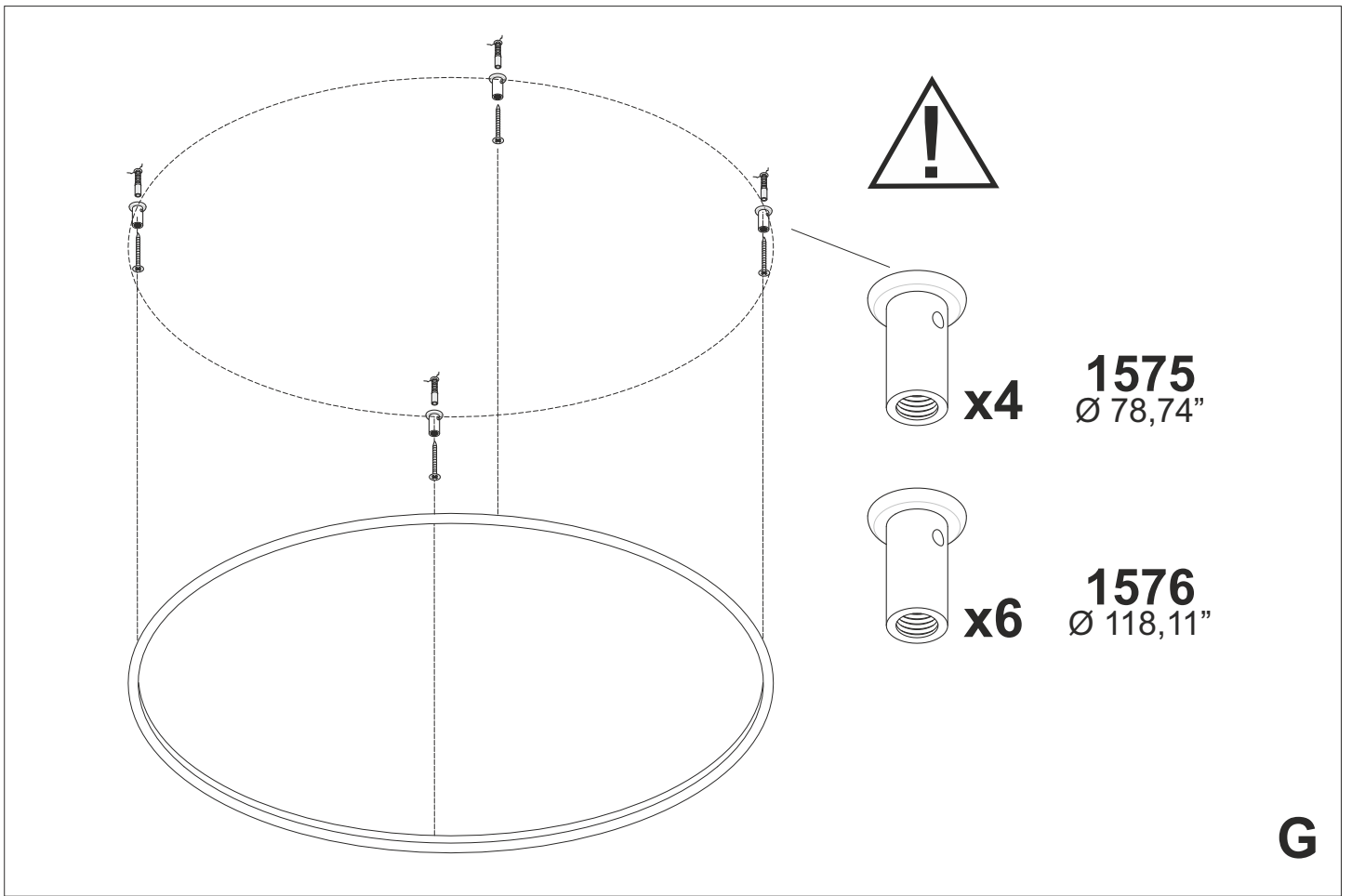

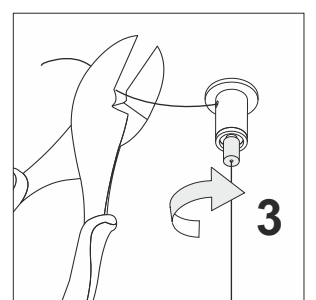
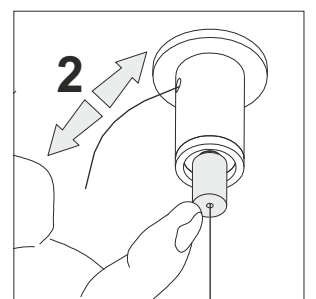
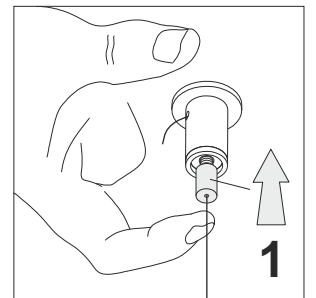
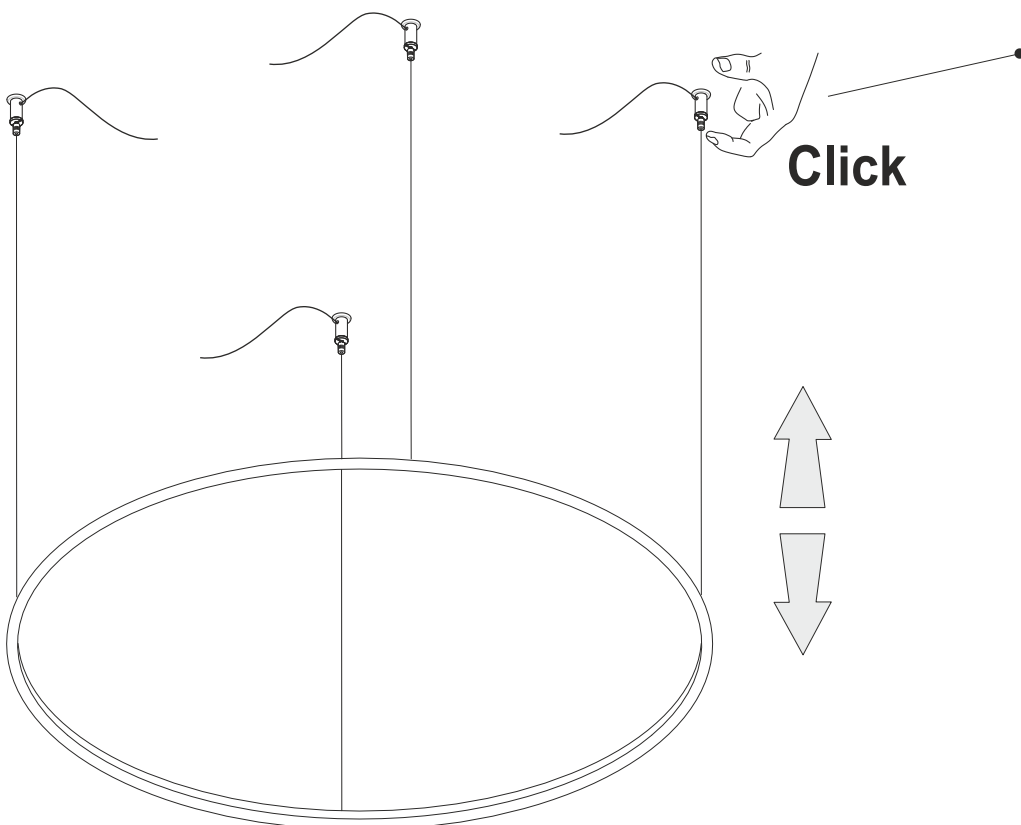
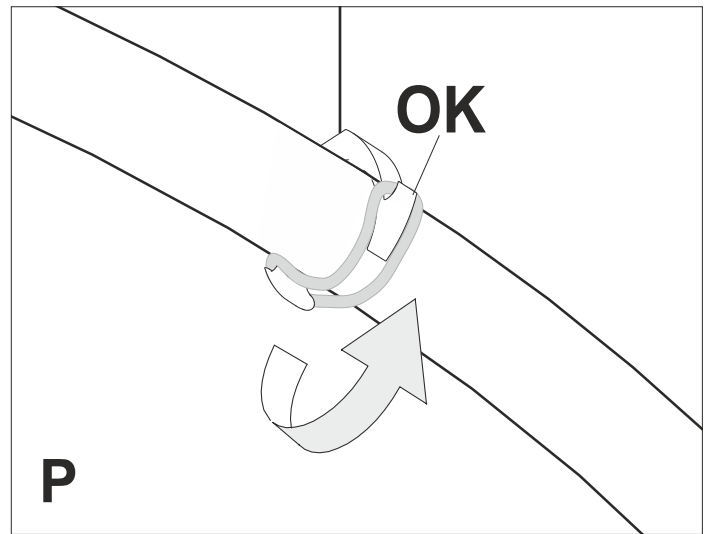
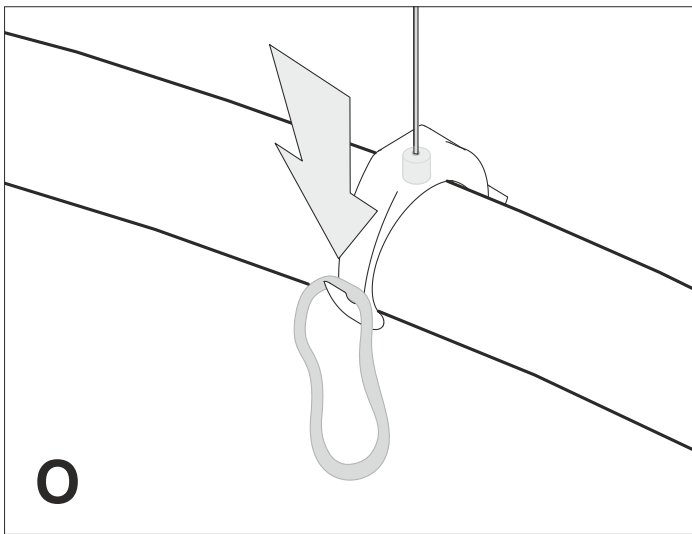
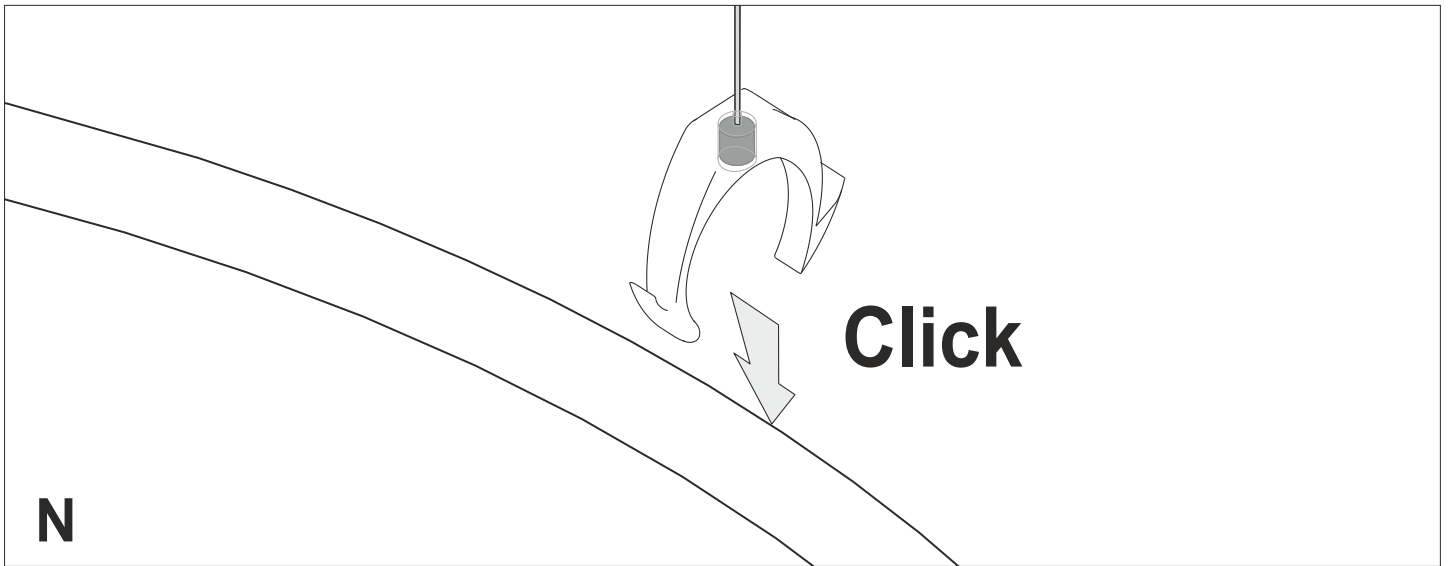

Per evitare di danneggiare il LED effettuare tutti i collegamenti prima di dare tensione

To avoid damages to LED unit all connection shall be made before to switch power on

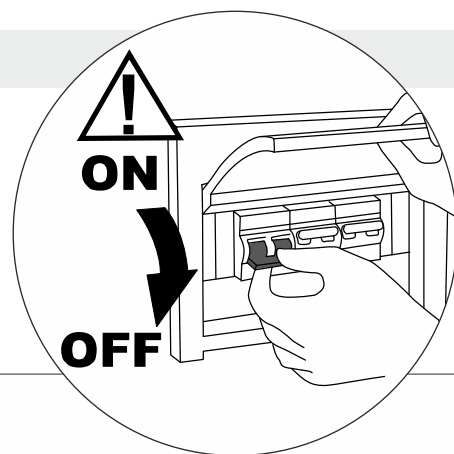

Q

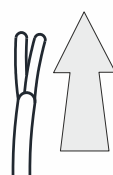
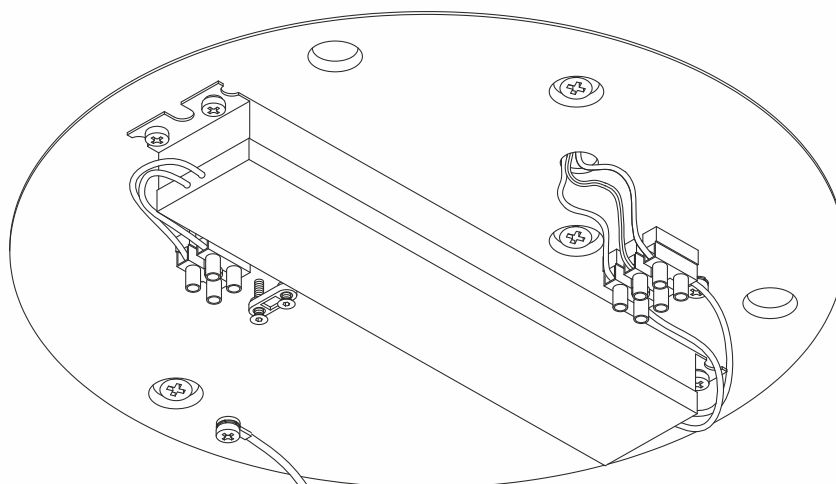

**LED
24V DC**

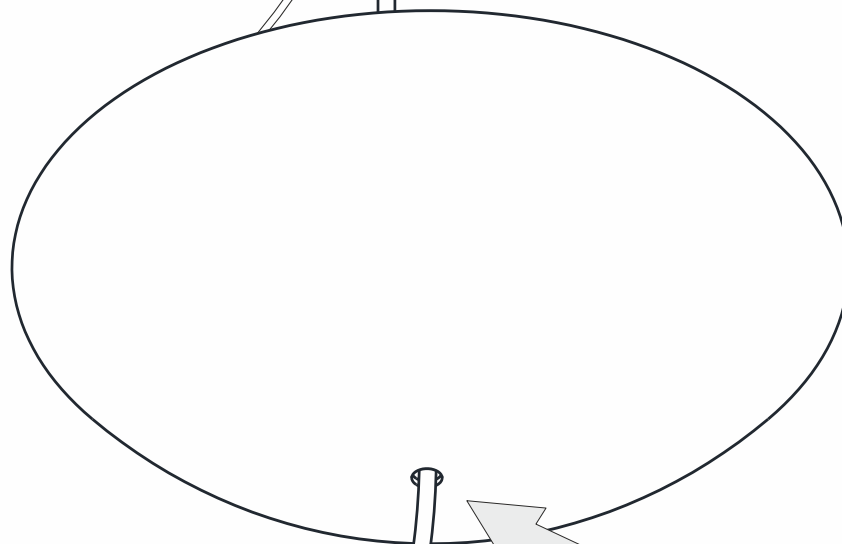

1575
Ø 78,74"
x1

1576
Ø 118,11"
x2

x2

Rispettare le polarita'
nel collegamento



*Respect correct
polarity when
connecting*

*Respectez la
polarité lors de
la connexion*

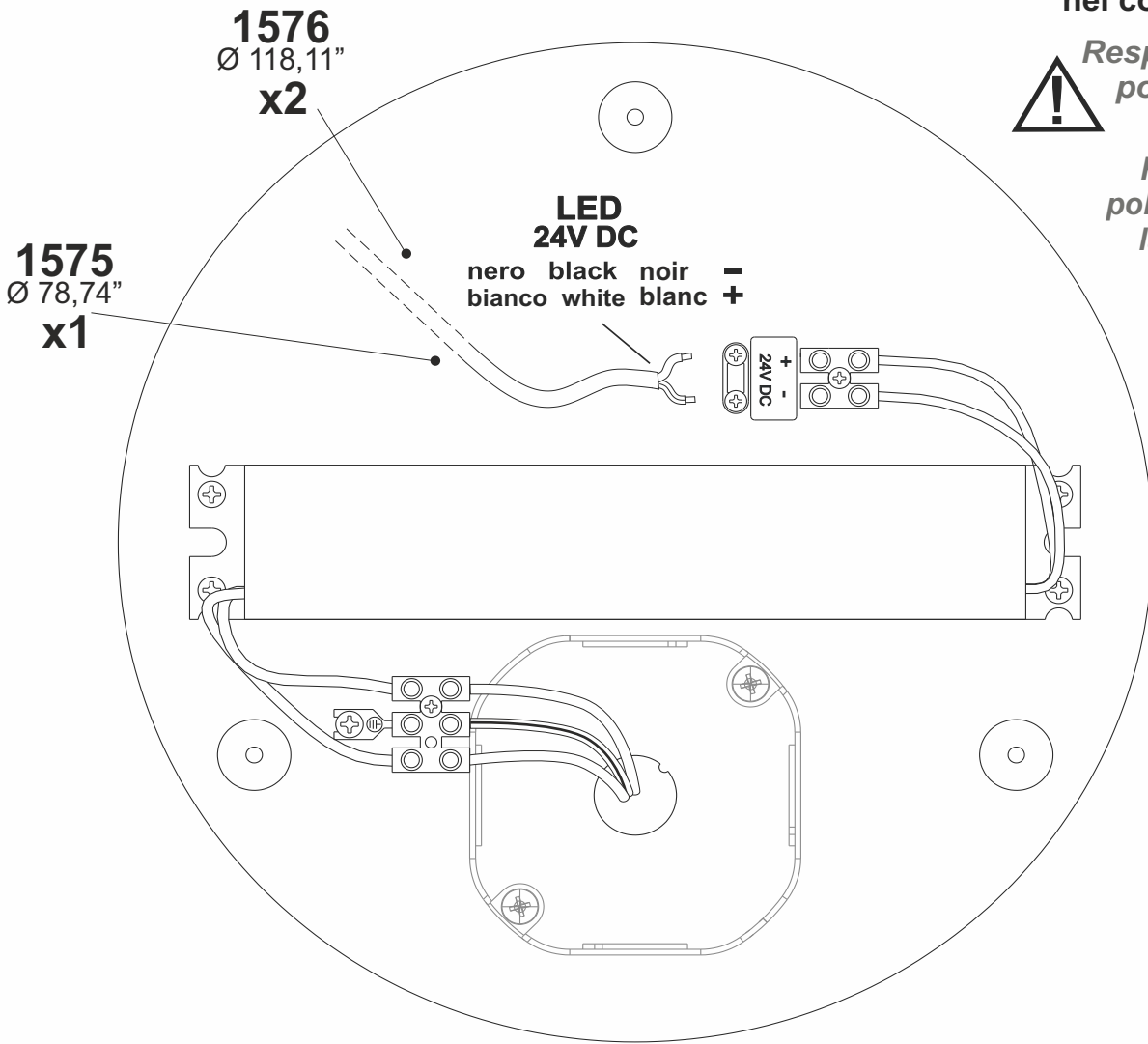

M

click

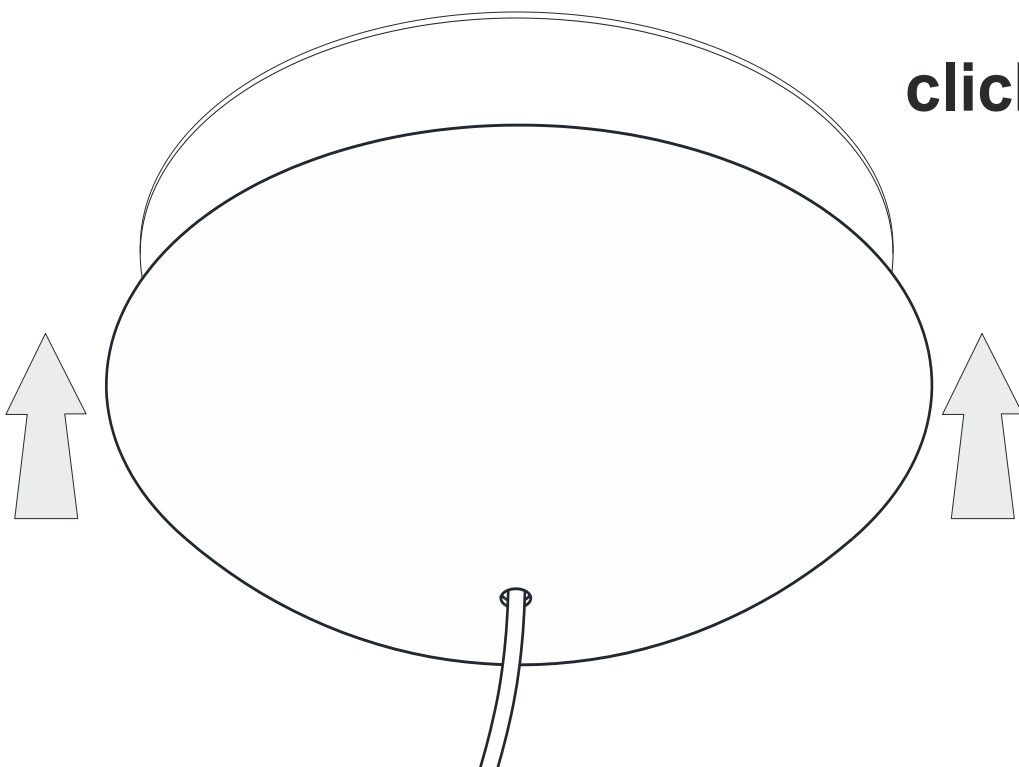



DRY LOCATION ONLY POUR EMPLACEMENTS SECS SEULEMENT

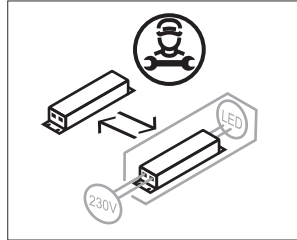
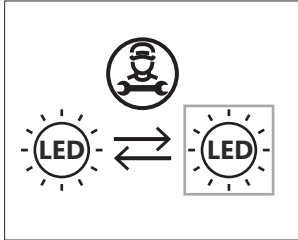

	<p>Apparecchio adatto ad essere installato su superfici normalmente infiammabili. Appareil pouvant être installé sur des surfaces normalement inflammables. Fixture ready for mouting on normally inflammable surfaces. Apparat, der auf normal entflammbare Oberflächen angebracht werden kann. Aparato idóneo para ser utilizado en superficies normalmente inflamables.</p>
	<p>Apparecchio in classe III. Class III luminaire. Appareil de classe III. Gerät der Klasse III. Aparato de clase III.</p>

	<p>Simbolo RAEE (Rifiuti Apparecchiature Elettriche ed Elettroniche). Il simbolo RAEE utilizzato per questo prodotto indica che quest'ultimo non può essere trattato come rifiuto domestico. Lo smaltimento corretto di questo prodotto contribuirà a proteggere l'ambiente. Per maggiori informazioni sul riciclaggio di questo prodotto, rivolgersi all'ufficio competente del proprio ente locale, alla società addetta allo smaltimento dei rifiuti domestici o al negozio dove è stato acquistato il prodotto.</p> <p>RAEE Symbol (Waste Electrical and Electronic Equipment). The use of the RAEE symbol indicates that this product may not be treated as household waste. By ensuring this product is disposed of correctly, you will help protect the environment. For more detailed information about the recycling of this product, please contact your local authority, your household waste disposal service provider or the shop where you purchased the product.</p> <p>Symbole RAEE (Waste Electrical and Electronic Equipment, Déchets électriques et d'équipement électronique). L'utilisation du symbole RAEE indique que ce produit ne peut pas être traité comme déchet domestique. Assurez-vous de vous débarrasser de ce produit selon les lois en vigueur. Vous aiderez ainsi à protéger l'environnement. Pour plus d'informations détaillées sur le recyclage de ce produit, veuillez contacter les autorités locales, le fournisseur de service de mise au rebut des déchets domestiques ou le magasin où vous avez acheté le produit.</p> <p>Symbol RAEE (Waste Electrical and Electronic Equipment). Durch Verwendung des RAEE-Symbols weisen wir darauf hin, dass dieses Produkt nicht als normaler Haushaltsmüll behandelt werden darf. Sie tragen zum Schutze der Umwelt bei, indem Sie dieses Produkt korrekt entsorgen. Genauere Informationen zum Recycling dieses Produkts erhalten Sie von Ihrer Stadtverwaltung, von Ihrem Müllabfuhrunternehmen oder im Laden, in dem Sie das Produkt erworben haben.</p> <p>Simbolo RAEE (Residuos de aparatos eléctricos y electrónicos). El símbolo RAEE en un producto indica que éste no se puede eliminar como cualquier otra basura. Si garantiza la eliminación correcta del producto, ayudará a proteger el medio ambiente. Para obtener más informaciones sobre el reciclaje del mismo, póngase en contacto con las autoridades locales pertinentes, con el proveedor de servicios de recogida de basura o con el establecimiento donde adquirió el producto.</p>
--	---