

# Wanda System

Design officinadiarchitettura&design

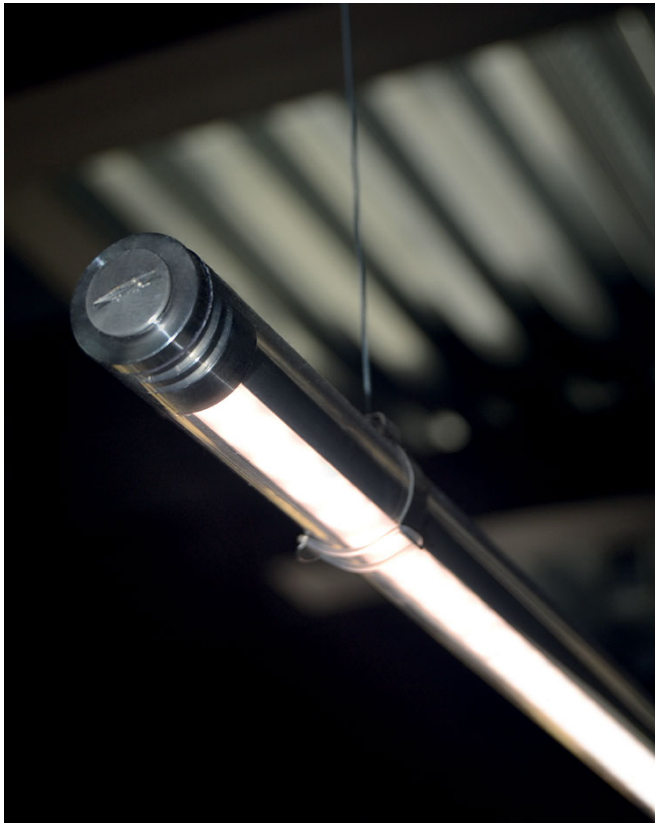

Code **1665.33/208 / \_ \_**

Description Suspension lamp made with an IP54 LED adjustable light bar made of transparent coextruded anti-UV methacrylate, AISI 316L stainless steel finials

Year of production 2020

Typology suspension

Material methacrylate/INOX AISI 316L

Light Emission *widespread*

IP grade 54

Allimentation 24Vdc

Finishes **.33** Brushed steel

Light source  
**/W** 30W 3680lm 24V 4000K CRI>90  
**/WW** 30W 3300lm 24V 3000K CRI>90  
**/XW** 30W 3120lm 24V 2700k CRI>90

Net weight 3,95 lb



98,43 inch

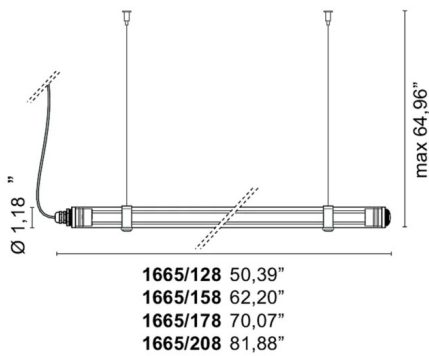

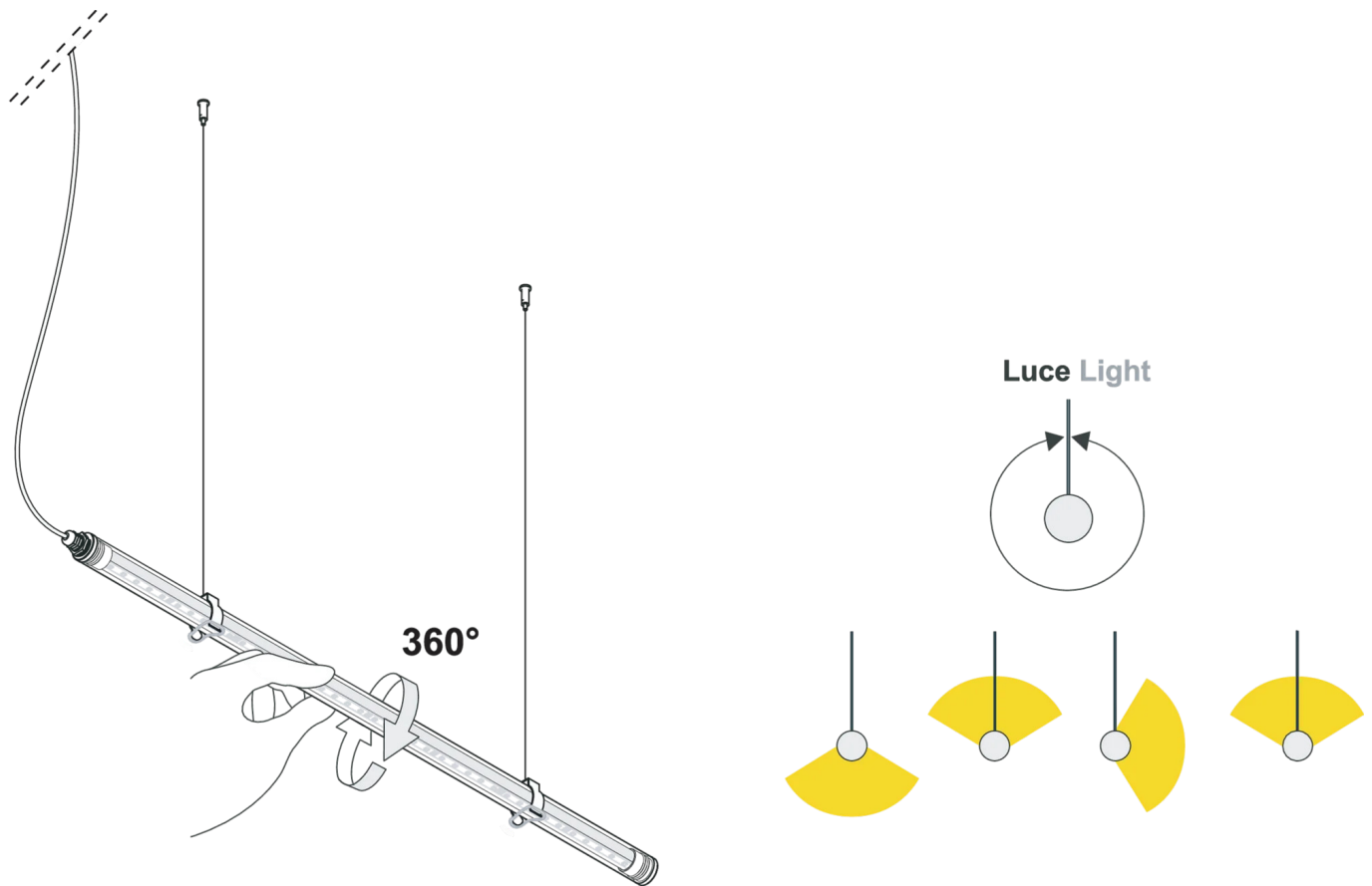

## ELEMENTI DI SISTEMA



20cm diameter rosette complete with 60W driver



### U0990/60

1,32 lb

- .01  White
- .02  Black
- .85  Painted silver
- .86  Painted gold
- .87  Painted copper
- .88  Bronze painted



30cm diameter rosette complete with 99W driver



### U0990/100

2,87 lb

- .01  White
- .02  Black
- .85  Painted silver
- .86  Painted gold
- .87  Painted copper
- .88  Bronze painted







38cm diameter rosette complete with 198W driver



## U0990/200

4,41 lb

- .01  White
- .02  Black
- .85  Painted silver
- .86  Painted gold
- .87  Painted copper
- .88  Bronze painted